

Electric Motor Driven

# Submersible Pump

Model 2XH5

Size 2"



## PUMP SPECIFICATIONS

- Size:** 2" 50.8 mm)
- Pump Casing:** Gray Iron
- Motor Casing:** Stainless Steel
- O-Rings:** Nitrile Rubber
- Wetted Hardware:** Stainless Steel
- Impeller:** Gray Iron
- Rotor Shaft:** Stainless Steel
- Lip Seal:** Nitrile Rubber

## MOTOR/CABLE SPECIFICATIONS

- Power Cable:** 3 Wire (2 Power Conductors, 1 Ground), 16/3 AWG, Type STOW (PVC). 30 Ft. (9 m) Long
- Standard Equipment:** Lifting Handle. 1 1/2" (38 mm) NPT Discharge Adaptor. Built-in Thermal Overload Protection.



*\*Consult Factory for Applications Exceeding Maximum Pressure and/or Temperature Indicated.*

**WARNING!**

Do not use in explosive atmosphere or for pumping volatile flammable liquids.

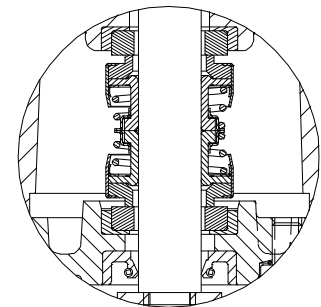
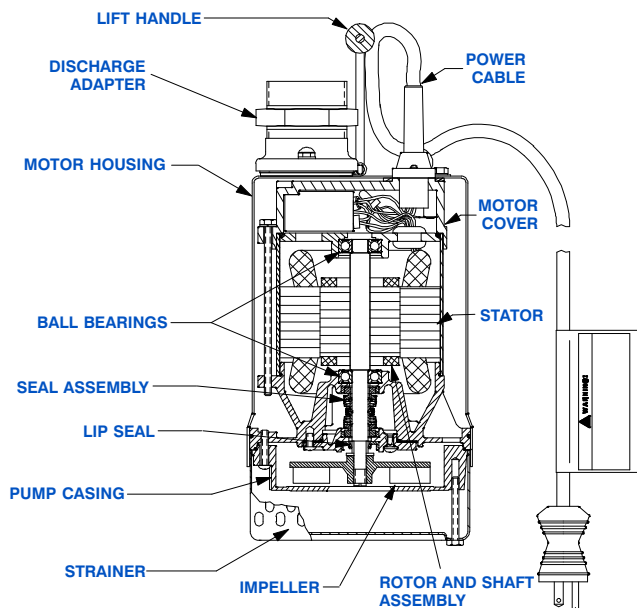

## SEAL SPECIFICATIONS:

Oil Lubricated. Double. Mechanical. Carbon/Ceramic Upper Seal Faces. Silicon Carbide/Ceramic Lower Seal Faces. Fluorocarbon Elastomers (DuPont Viton® or Equivalent).

Maximum Temperature of Liquid Pumped, 104°F (40°C).\*



GORMAN-RUPP PUMPS

www.grpumps.com

Specifications Subject to Change Without Notice

Printed in U.S.A.

**Specification Data**

SECTION 130, PAGE 241C

APPROXIMATE  
DIMENSIONS and WEIGHTS

PUMP and CABLE NET WEIGHTS:\*

28 LBS. (12,7 KG.)

\*Add 6 LBS. (2,72 KG.) to Net Weights for Cartoned Weights.

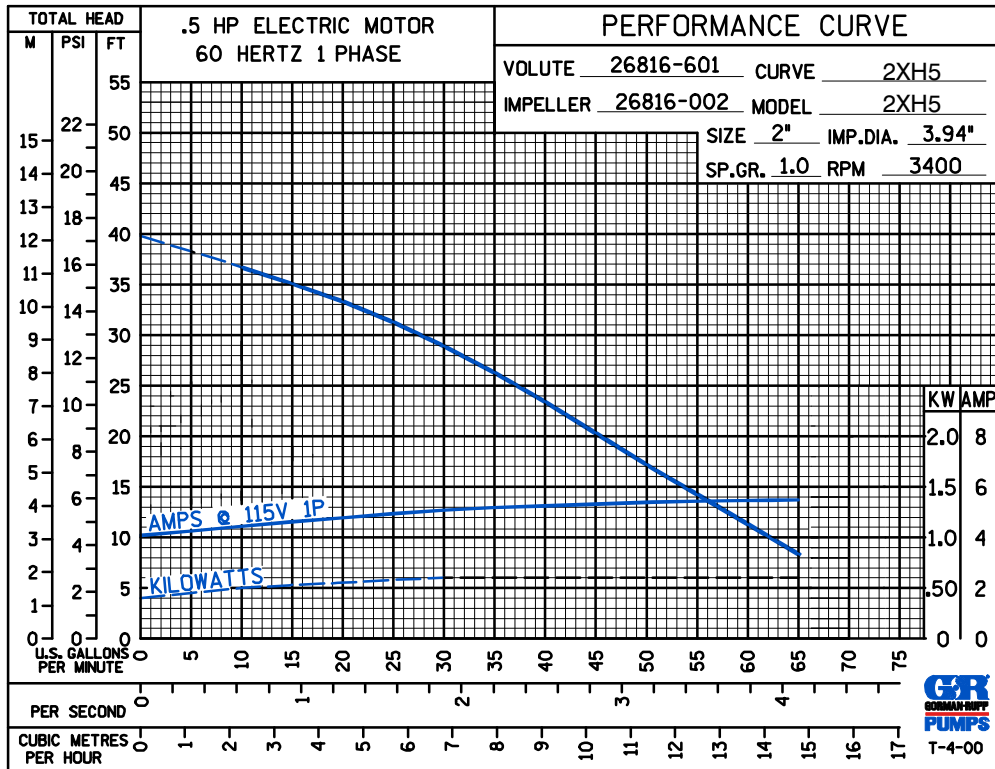
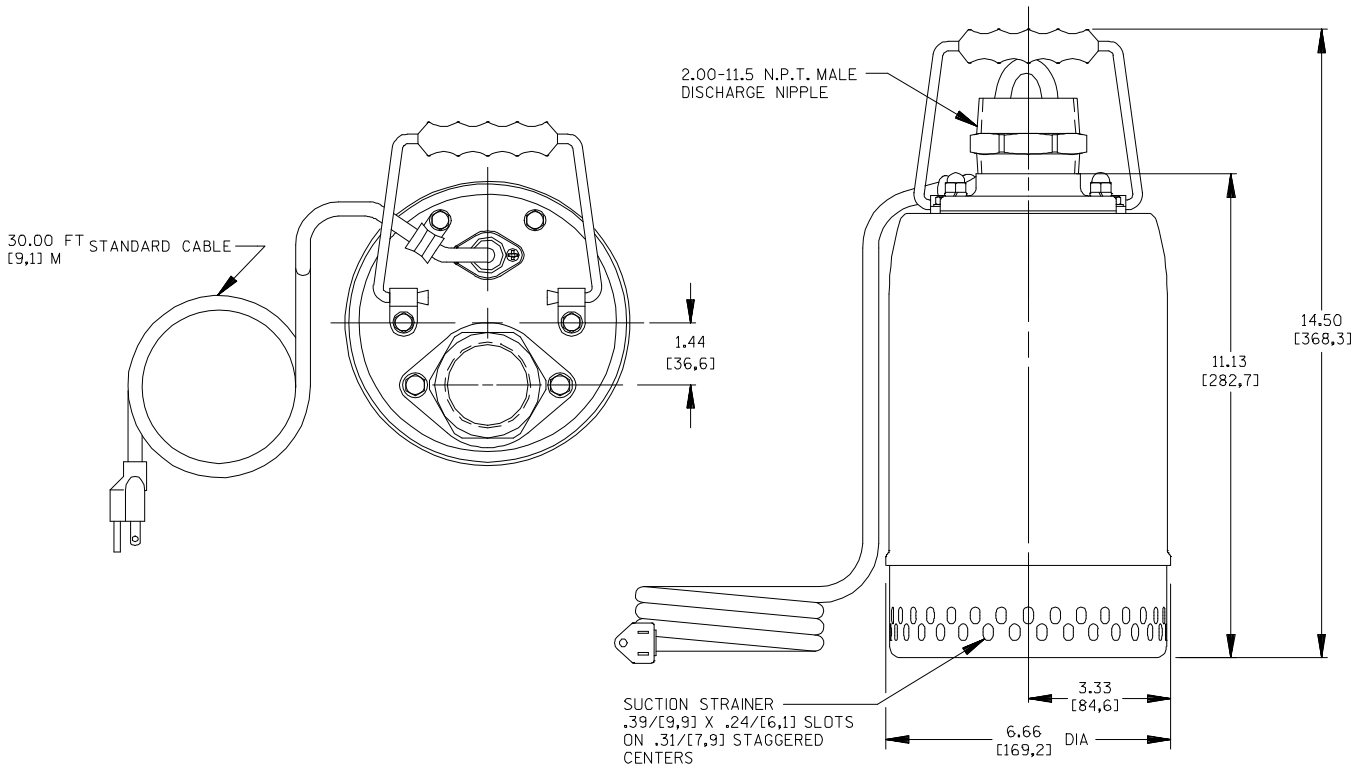

**GORMAN-RUPP PUMPS**

www.grpumps.com

Specifications Subject to Change Without Notice

Printed in U.S.A.